

Agathon Guiding System Plus

6701 | 7231 | 8005

Standardized main guide –
Guiding and Centering all in One



AGATHON

Conventional guiding and centering concept

Conventional flat centering for precise alignment when closing the mold

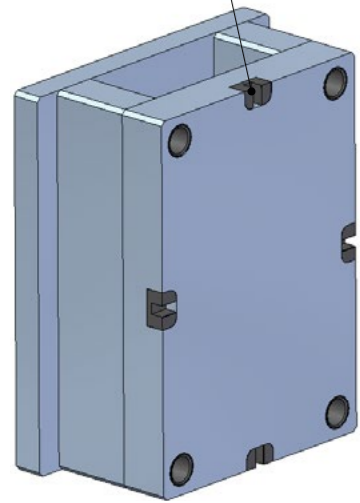

Main guide for rough alignment when closing and assembling

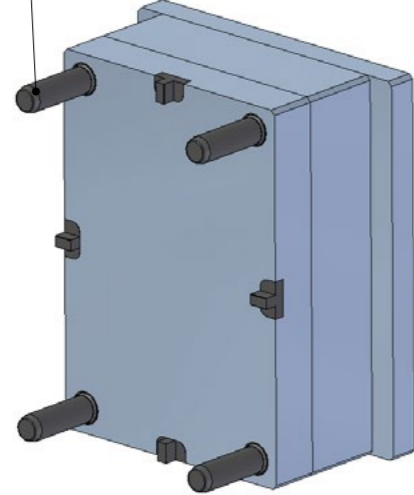

- Two different systems in the mold
- Main guide only takes over the rough alignment of the tool during assembly
- Conventional flat centering takes over the precise alignment on the last millimeters of the closing stroke
- Problematic with long, spotting or sensitive mold areas
- Relatively high wear

Guiding and centering concept with Agathon Guiding System Plus

Rolling bush system 7231 for backlash-free guiding and centering over the entire closing stroke

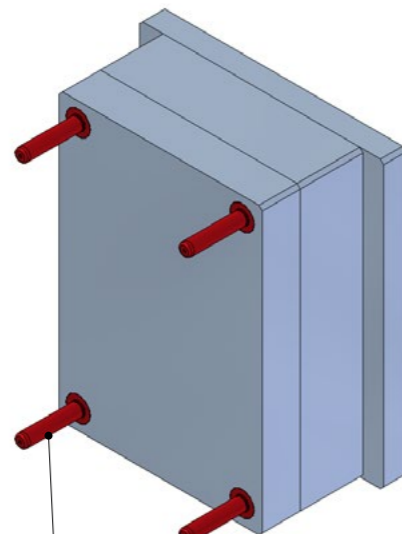
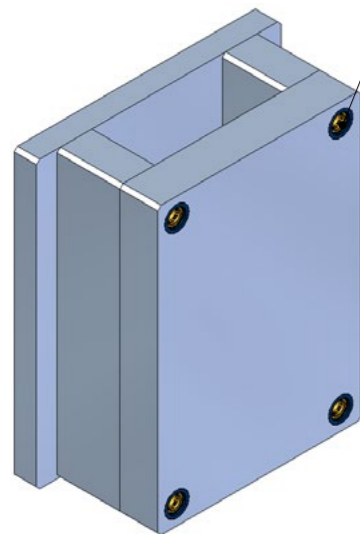

System guide pillar 6701

- The Agathon Guiding System Plus performs the guiding and centering tasks with only one system
- Highest precision due to preloaded roller guide
- Reliably prevents slipping and jerking during mold movements
- Extremely simple handling: Low maintenance, durable, not paired despite roller guide
- Almost free of wear

Cost comparison Conventional concept

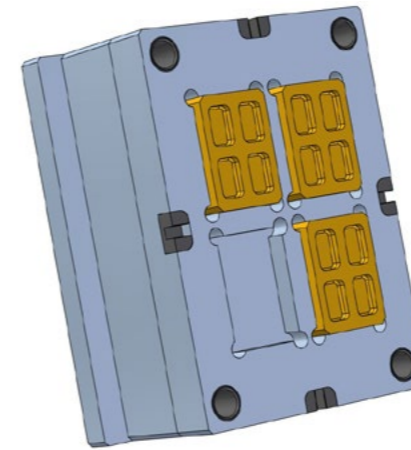

- Four main guides and four conventional flat centering devices are required
- Pocket production for conventional flat centering is costly, time-intensive and inaccurate
- Space requirement for main guide and conventional flat centering is high
- Precision depends on manufacturing tolerances and wear condition of the guiding and centering elements
- High lubrication and maintenance requirements
- Dirt penetration due to abrasion and particle formation

Agathon Guiding System Plus

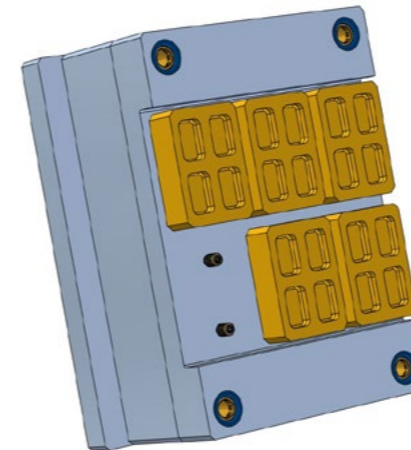

- Guiding and centering combined in one device
- Pocket manufacturing for conventional flat centering is no longer necessary, this saves time and costs
- Working surface increased by approx. 30% for additional cavities, sliders and thermoregulation
- Backlash-free guidance with profile rollers ensures that precision remains at the highest level throughout the entire lifespan
- Low lubrication and maintenance requirements increase productivity, reduce maintenance costs and protect the environment

With Agathon Guiding System Plus, you increase your planning reliability in production, boost productivity and reduce overall production costs.

Retaining ring (flexible collar)

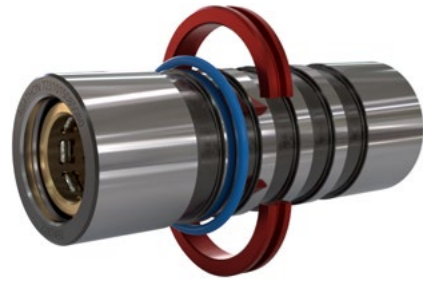

- Through individual positioning of the retaining ring, several plate thicknesses are covered with one product
- Can be used with roller bushing system 7231 and system guide pillar 6701
- Can be re-ordered as spare part (Standard 8005)
- Securely fixed by heat-resistant O-ring (up to 200 °C / 392 °F)

Profile rollers



- Rolling instead of sliding: less wear
- Highest load capacity and stiffness
- Line contact between pillar, rolling element and bushing
- Highest precision due to zero backlash
- Travel speeds of up to 40 m/min possible

Long centering stroke

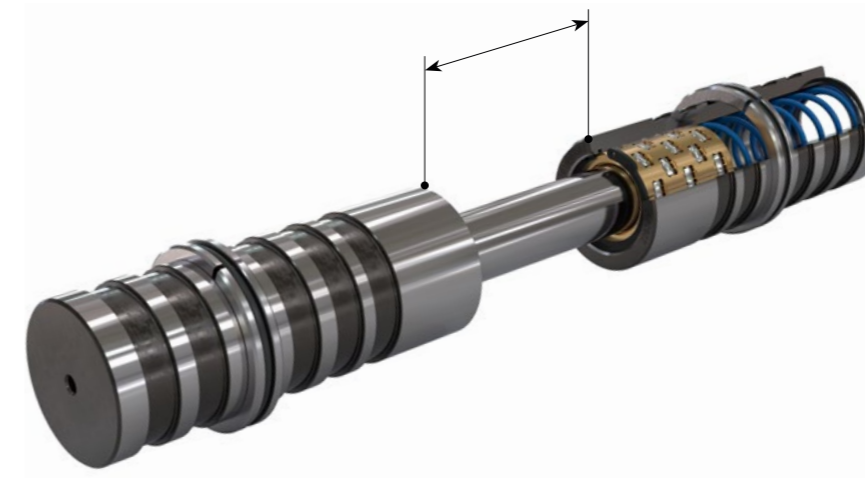

- Tool is already well centered before complete shut-off
- Abrasion on the spotting area and the plunger cores is prevented
- Tool life is increased

Optimized for high-end applications



- Minimum lubrication is sufficient
- Brass cage allows cleaning in ultrasonic bath and temperatures up to 170 °C / 338 °F
- Ideal for clean room, high precision, micro injection molding and high temperature applications
- Significantly higher travel speeds and therefore higher production output is possible

Technical Data

System guide pillar 6701

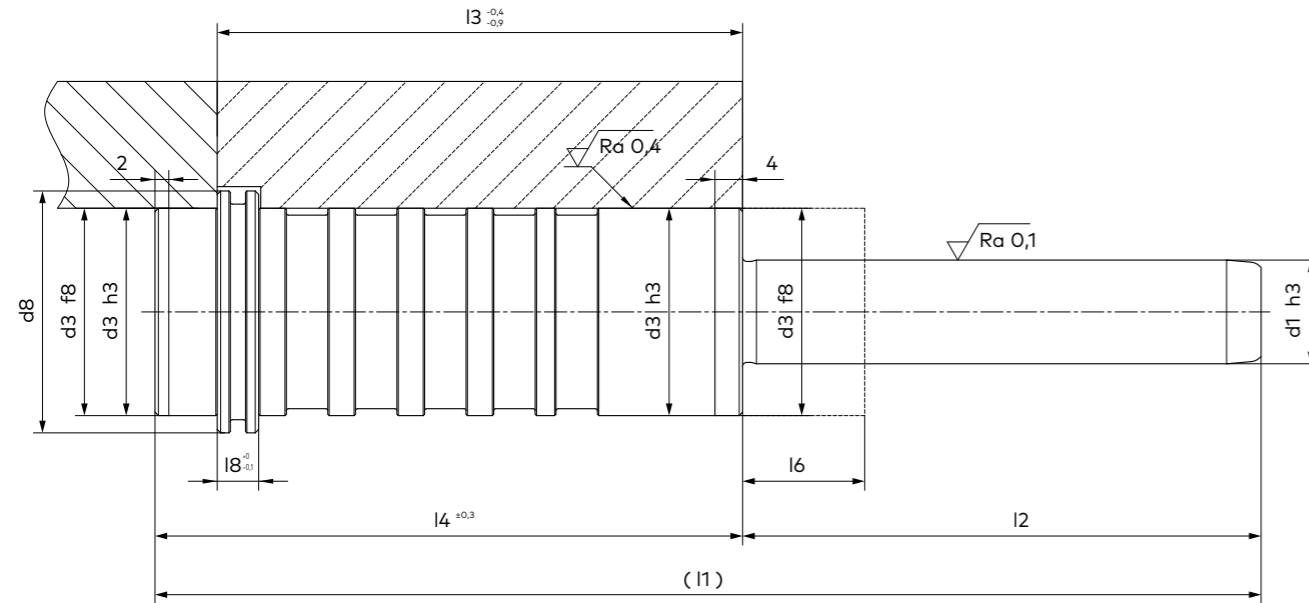

d1 = Pillar diameter, tolerance h3, superfinish ground
 d3 = Outer diameter of the guide pillar to fit h3/H5(H6)
 d8 = Outer diameter of the retaining ring (flexible collar)
 l1 = Total length of the guide pillar
 l2 = Length of diameter d1
 l3 = Installation positions of the retaining ring (flexible collar)
 l4 = Length of installation diameter d3
 l6 = Permissible thickness of the stripper plates
 l8 = Width of the retaining ring (flexible collar)

Note:
 l2 can differ from usual standards. Check the possible application in tight spaces

See page 9 for installation tolerances

Material: 100Cr6, hardened 62-64 HRC, edge layer hardened, depth 1.5+1 mm;
 Temperature resistance: up to approx. 170 °C / 338 °F
 Extent of supply: incl. 1 retaining ring Standard 8005 in the respective diameter

Article	d1	d3	d8	l1	l2	l3	l4	l6	l8
6701.015.075.085	15	30	35	160	75	27; 36; 46; 56; 66; 76	85	<27	6
6701.015.102.085	15	30	35	187	102	27; 36; 46; 56; 66; 76	85	27-46	6
6701.015.121.085	15	30	35	206	121	27; 36; 46; 56; 66; 76	85	46-56	6
6701.015.141.085	15	30	35	226	141	27; 36; 46; 56; 66; 76	85	56-76	6
6701.025.080.095	25	42	47	175	80	27; 36; 46; 56; 66; 76; 86	95	<27	6
6701.025.116.095	25	42	47	211	116	27; 36; 46; 56; 66; 76; 86	95	27-46	6
6701.025.136.095	25	42	47	231	136	27; 36; 46; 56; 66; 76; 86	95	46-56	6
6701.025.156.095	25	42	47	251	156	27; 36; 46; 56; 66; 76; 86	95	66-76	6
6701.032.095.108	32	54	59	203	95	36; 46; 56; 66; 76; 86; 96	108	<27	10
6701.032.131.108	32	54	59	239	131	36; 46; 56; 66; 76; 86; 96	108	27-46	10
6701.032.151.108	32	54	59	259	151	36; 46; 56; 66; 76; 86; 96	108	36-56	10
6701.032.171.108	32	54	59	279	171	36; 46; 56; 66; 76; 86; 96	108	66-76	10
6701.040.115.128	40	66	71	238	115	56; 66; 76; 86; 96; 106; 116	128	<46	10
6701.040.161.128	40	66	71	284	161	56; 66; 76; 86; 96; 106; 116	128	46-66	10
6701.040.181.128	40	66	71	304	181	56; 66; 76; 86; 96; 106; 116	128	66-86	10

Technical Data

Rolling bush system 7231

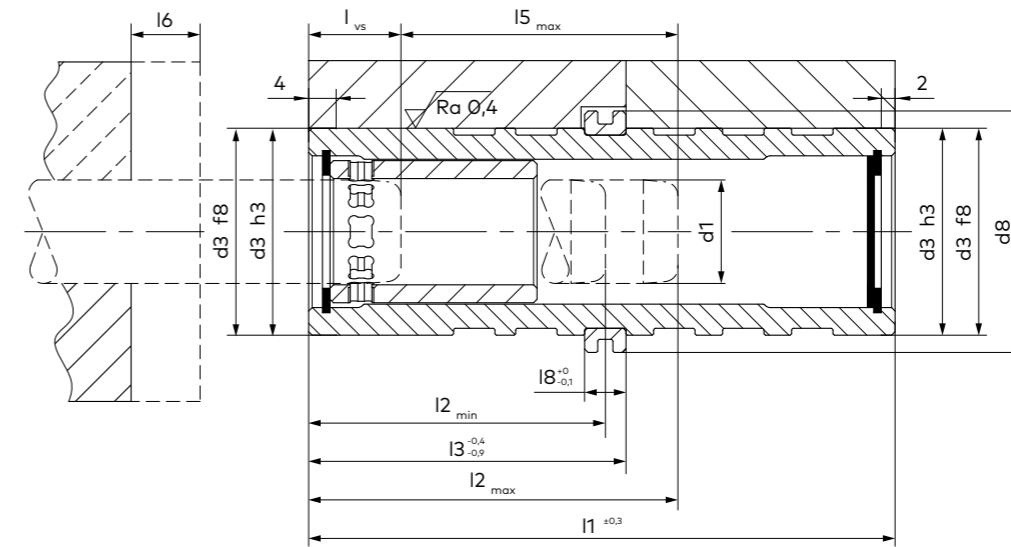

Illustrated situation: Entry into preload, start guiding/centering. The guide is designed in such a way that it can be moved completely out of the preload (complete opening of the tool), e.g. for robot part removal

d1 = Corresponding pillar diameter
 d3 = Outer diameter of the guide bushing
 d8 = Outer diameter of the retaining ring (flexible collar)
 l_{vs} = Entry into the preload (l_{2max} - l_{5max})
 l1 = Total length of the guide bushing
 l_{2min} = Recommended minimum immersion depth using the shortest pillar type 6701 with the thickest support plate l6
 l_{2max} = Maximum immersion depth when using longer pillars
 l3 = Installation positions of the retaining ring (flexible collar)
 l_{5max} = Maximum possible centering stroke when using longer pillars
 l6 = Stripper plate (see Standard 6701)
 l8 = Width of the retaining ring (flexible collar)
 f_{max} = Maximum centering offset at centering start
 C = Dynamic load capacity in [N] - initial load capacity

Notes:
 The values l_{2max} l_{5max} must never be exceeded
All load capacities are indicative values
 C₀ = static load capacity in N at l_{2max} tool shut
 C_{0maxP} = static load capacity in N at immersion depth l_{2min} (when using thickest recommended stripper plate l6)

See page 9 for installation tolerances

Recommendations:
 Minimum immersion depth l_{2min}
 Reduce immersion depth in case of higher required lifespan (cycles)

Material of bushing and rollers: 100Cr6 (1.3505), hardened 62-64 HRC
 Material of the cage: Brass CuZn39Pb3 (2.0401)
 Temperature resistance: up to approx. 170 °C / 338 °F
 Extent of supply: incl. 1 retaining ring Standard 8005 in the respective diameter

Article	d1	d3	d8	l1	l2 _{max}	l3	l5 _{max}	l8	C [N]	C ₀ (l _{2max}) [N]
7231.015.085.080	15	30	35	85	80	27; 36; 46; 56; 66; 76	62	6	1850	5600
7231.025.095.086	25	42	47	95	86	27; 36; 46; 56; 66; 76; 86	67	6	2400	8700
7231.032.108.100	32	54	59	108	100	36; 46; 56; 66; 76; 86; 96	78	10	3650	13200
7231.040.128.122	40	66	71	128	122	36; 46; 56; 66; 76; 86; 96; 106; 116	100	10	4950	21000

Article	d1	f _{max}	l _{2min}	C _{0maxP} [N]
7231.015.085.080	15	0,20	48	4500
7231.025.095.086	25	0,20	53	5800
7231.032.108.100	32	0,20	68	11000
7231.040.128.122	40	0,20	69	15000

Version in Ø15 and Ø25 mm

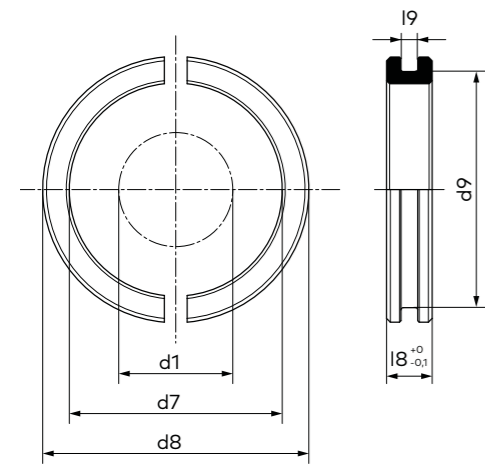

Version in Ø32 and Ø40 mm

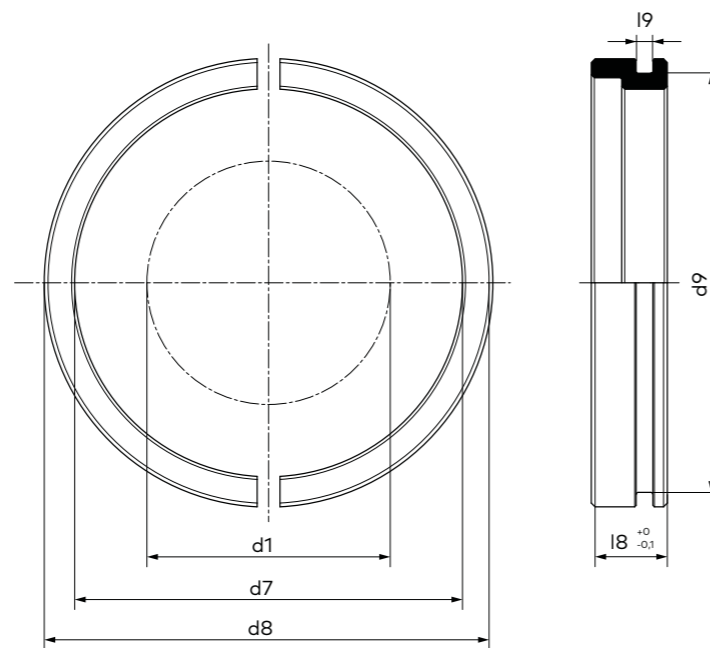

- d1 = Corresponding pillar diameter
- d7 = Inner diameter of the retaining ring (flexible collar)
- d8 = Outer diameter of the retaining ring (flexible collar)
- d9 = Diameter of the groove for O-Ring
- l8 = Width of the retaining ring (flexible collar)
- l9 = Width of the groove for O-Ring

Material of retaining ring: 44SMn28 (1.0762); Material of O-Ring: Fluorocarbon rubber (FKM/FPM) ±

Temperature resistance: up to approx. 200 °C / 392 °F

Extent of supply: 1 retaining ring (two-part), 1 O-Ring FKM/FPM

Article	d1	d7	d8	d9	l8	l9
8005.015.006	15	28	35	31,2	6	2,2
8005.025.006	25	39	47	43,2	6	2,2
8005.032.010	32	51	59	55,2	10	2,2
8005.040.010	40	62	71	67,2	10	2,2

Installation of the retaining ring for version ø 32/40

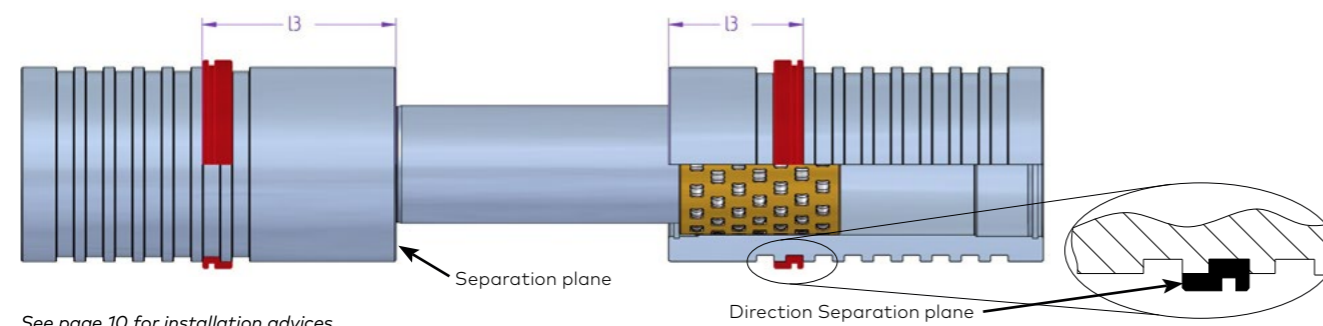

See page 10 for installation advices

Installation tolerances for system guide pillar 6701 and rolling bush system 7231

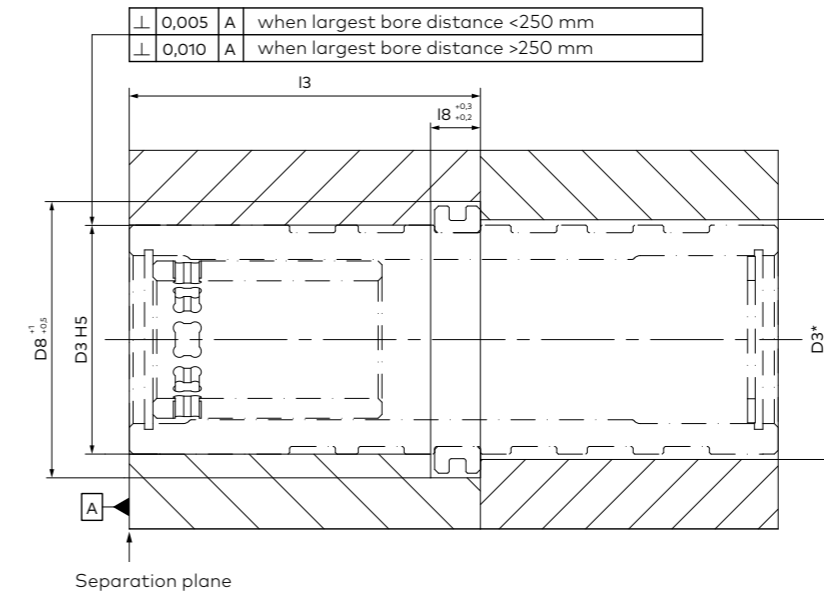

- The pillar and bushing are installed in bores with tolerance H5
- Alternatively, tolerance H6 can be used for lower precision requirements

* = For easier installation – depending on the required precision – the following plates can be released

The nominal dimensions of bores D3 and D8 correspond to the outer diameter d3 of the guide bushing and d8 of the retaining ring.

Perpendicularity

If the largest bore distance of the main pillar bores is less than 250 mm, the perpendicularity of the locating bore to the separation plane should be <0.005 mm on 100 mm length of the guide pillars.

If the largest bore distance of the main pillar bores is larger than 250 mm, the perpendicularity of the locating bore to the separation plane should be <0.010 mm on 100 mm length of the guide pillars.

Position tolerances

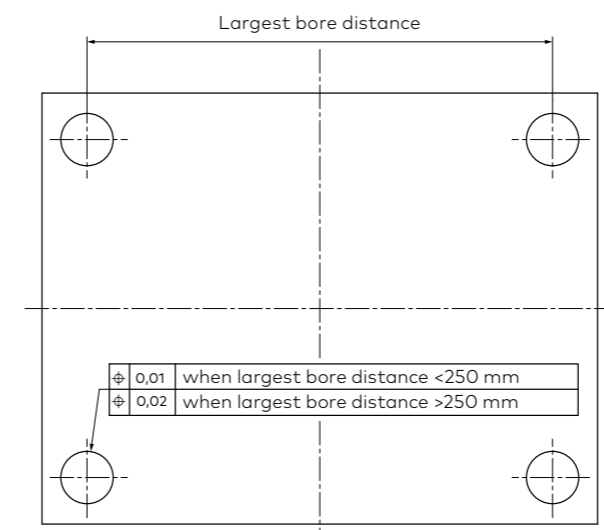

- If the largest bore distance between the main pillar bores is less than 250 mm, the positioning accuracy should be <0.01 mm (i.e. ±0.005 mm)
- If the largest bore distance between the main pillar bores is larger than 250 mm, the positioning accuracy should be <0.02 mm (i.e. ±0.01 mm)
- Recommendation for best performance: predrilled plates with grinding allowance to the desired tolerance or have plates produced with recommended tolerance

Installation

- Clean and remove corrosion protection before installation, then lubricate
- Position retaining ring correctly, insert O-Ring
- Tap the fit with light knocks, use rubber hammer or spacer
- Do not knock on circlip or retaining ring

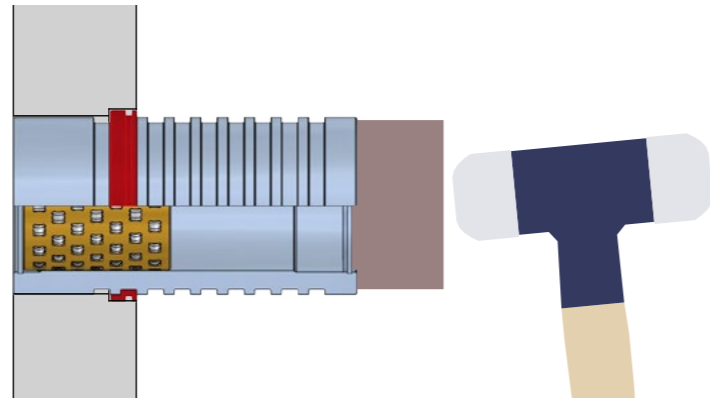

Removal

- Use rubber hammer or spacer
- Do not knock on circlip, retaining ring or cage
- Do not pull on retaining ring

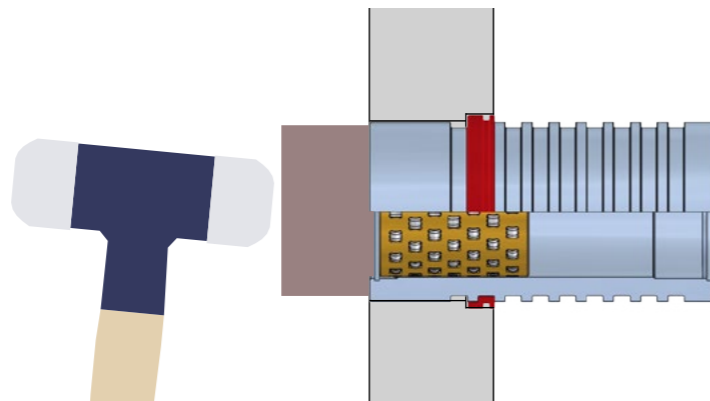

Maintenance

- Regular 60° rotation of bushing and pillar
- First remove old grease completely, then apply new grease
- Minimum lubrication is sufficient
- When replacing the O-Ring, observe temperature resistance (FKM/FPM)

Calculation example

Results rounded off

$$m = (L \cdot B \cdot H \cdot \rho) / 10^9 = (246 \text{ mm} \cdot 346 \text{ mm} \cdot 298 \text{ mm} \cdot 7850 \text{ kg/m}^3) / 10^9 = 199 \text{ kg}$$

$$F_G = (m \cdot g) / 2 = (199 \text{ kg} \cdot 9,81 \text{ m/s}^2) / 2 = 976 \text{ N}$$

$$F_{G_{Sys}} = F_G / n = (976 \text{ N}) / 4 = 244 \text{ N}$$

Check, if $F_{G_{Sys}} < C$ (e.g. 7231.015.085.080):
244 N < 1850 N – the load capacity is sufficient!

Legend:

F_G = Weight force of a mold half [N]

$F_{G_{Sys}}$ = Weight force per rolling bush system [N]

n = Number of installed rolling bush systems (usually 4 pcs.)

C = Initial dynamic load capacity of a rolling bush system [N]

m = Weight of the injection mold [kg]

g = Gravitational constant 9.81 m/s²

L = Length of the tool [mm]

B = Width of the tool [mm]

H = Installation height of the tool [mm]

ρ = Density of the tool [kg/m³] Approximation: $\rho_{\text{Stahl}} = 7850 \text{ kg/m}^3$

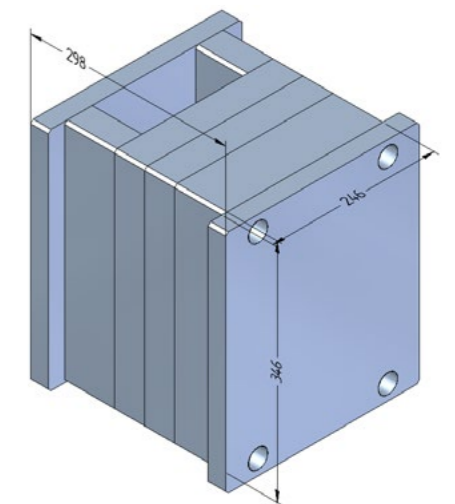

Thermal expansion in injection mold

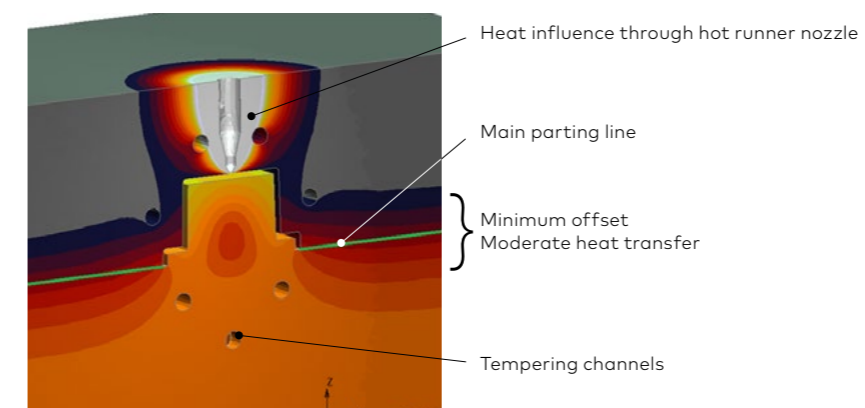

Conclusion:

For homogeneously tempered tools up to ΔT of 30 K, no problems are to be expected with thermal expansion.

- Case study: asymmetrically tempered tool, $\Delta T = 50 \text{ K}$
- Temperature: Ejector side 90 °C (194 °F)
Nozzle side 40 °C (104 °F)
- Actual offset is reduced by a **factor of 3-5** by heat transfer at the tool separation!
- Analyzed offset at separation: 6,2 μm > Agathon Guiding System Plus can be used

More information can also be found in our factsheet.

Guidance of a stripper plate

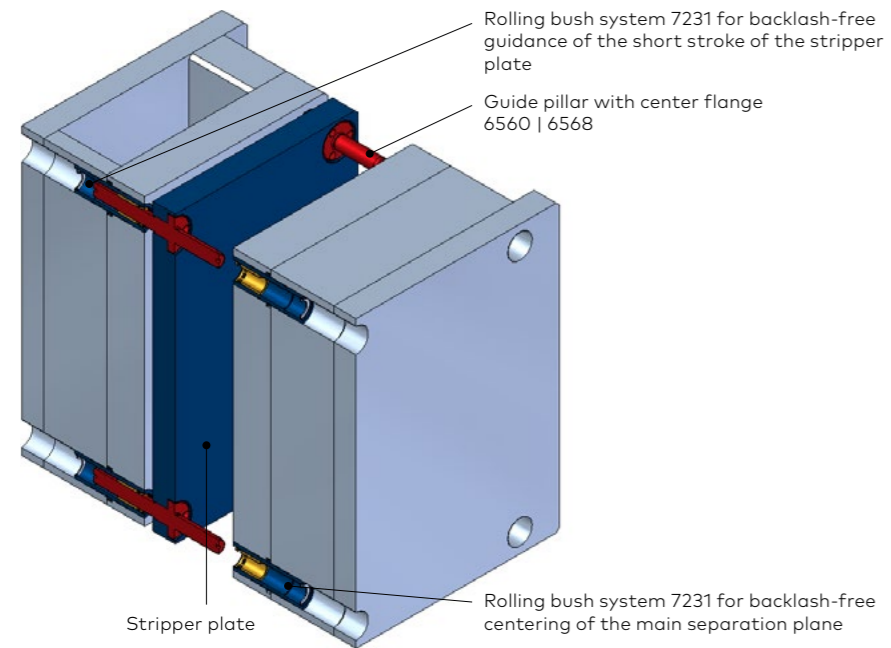

- Stripper plate is guided backlash and stick-slip-free by a rolling bush system
- Abrasion on mold cores, particle formation and wear is minimized
- Additional rolling bush system closes the main separation plane backlash-free and with high precision
- Long lifespan, high stiffness, no tilting and no stick-slip of plates

Guidance of a stripper plate on the pillar

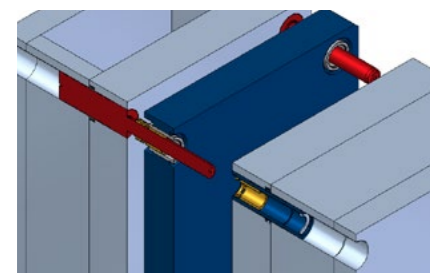

- Stripper plate is guided on the system guide pillar by backlash-free rolling guide system e.g. with Standard 7801/7611
- Durable, low-maintenance guiding solution
- Entire length of the pillar can be used for the guiding stroke
- Tilting and stick-slip are reliably prevented, part quality increases and wear is minimized

Guidance of an ejector plate (short stroke)

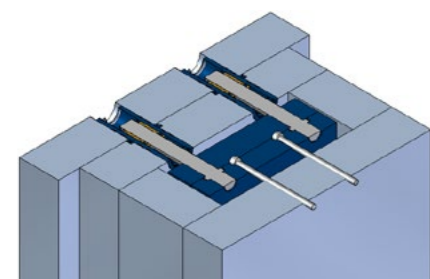

- Stripper plate is guided with Standard 7231/6571
- High stiffness protects the ejectors and their bores in the mold inserts
- Ready-to-install solution, available from stock
- Smooth, controlled and stick-slip-free movement of the ejector plates
- Ideal for clean rooms due to minimum lubrication and long lifespan

Main guide in stack molds

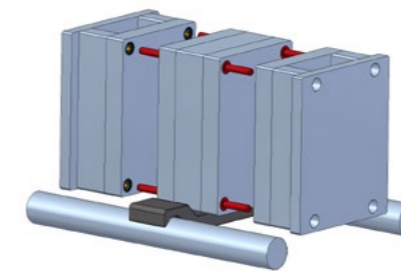

- Support of the center plate is required for long strokes and very high force weight
- Support of the center plate is not required for short strokes
- Can also be used for cube molds due to unpaired units

Main guide for turning tools

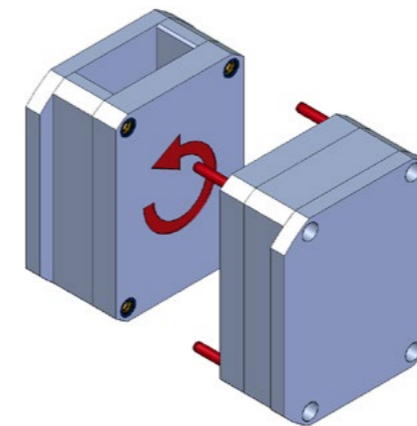

- Highest precision even with multi-component molds
- Durable, low-maintenance guiding solution
- The units do not need to be paired due to tight tolerances
- Ensures highest precision in both stations and therefore protects separation and spotting areas

Centering for handling

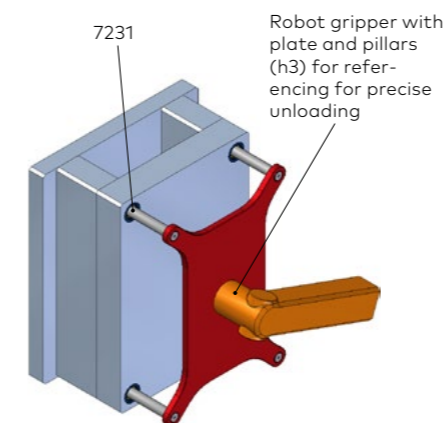

- High stiffness eliminates vibrations of the handling head
- High travel speeds of the robot are possible due to profile rollers
- Highest precision due to backlash-free end centering during part unloading

Flexibility – One for all



- Flexible collar: Only one size in stock necessary due to flexible collar concept. The main guide can continue to be used if the mold and plate thicknesses are changed
- Compatibility: Retrofitting of the mold possible without rework on plates
- Without pairing: Any pillar from the Agathon product range can be combined with Standard 7231. **Attention:** Do not exceed $I2_{max}$
- Spare parts available from stock

Better utilization of the mounting surface

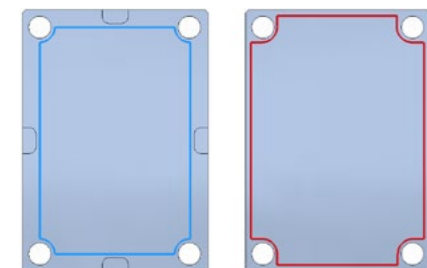

- No separation between main guide and end centering
- Simplified tooling: fewer components and less space required on the mounting surface, significantly reduced manufacturing and assembly effort
- More cavities = higher productivity on the same mounting surface
- When retrofitting the Agathon Guiding System Plus, any existing conventional flat centering units can be removed

Lifespan and precision

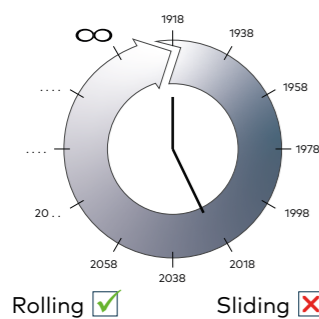

- Backlash-free guidance with profile rollers ensures maximum precision and part quality over the entire service life
- The lifespan is 5-12 times longer than that of conventional systems
- High process reliability reduces defective part production and production stops
- Less maintenance required, fewer production interruptions, higher productivity

Agathon Fine Centering Plus

- The right product for every application thanks to diameters of 10, 15, 25, 32, 40 and 50 mm
- The standard for highest precision
- For small, space-saving applications such as floating cavities
- For applications up to 170 °C / 338 °F, for long centering strokes and clean room applications
- Solution for short-stroke applications such as stripper plates and venting strokes



Agathon Mini Fine Centering

- Centering for highly precise and light centering tasks – including for short-stroke applications
- For applications in punching and injection molds, mechanical engineering, robotics and automation
- Stick-slip-free movement, low wear, maximum precision and minimum space requirement
- Bushing and pillar unit are not paired and can be replaced individually
- Available as complete unit with bushing (Standard 7981), as pillar unit (Standard 7980) and as bushing (Standard 7989), each in diameters 8 and 10 mm



Agathon Rolling guides for 24/7 operation

- Mass production in continuous operation: 24/7 production
- Mold concepts with sensitive inserts and multi-plate molds, thin-wall and multi-component injection molding
- High-precision demolding of long mold cores
- For stack molds, with or without support of the center part



AGATHON

STRIVE FOR THE BEST.